

RAMCO WASHER MAINTENANCE

SAFETY REGULATIONS

Safety regulations must be followed while operating and maintaining the machines. This information applies all machine operators.

Warning: These washers/extractors must be installed, adjusted and maintained by qualified persons who are familiar with their structure and operation. Ignoring these instructions may cause injury to a person and damage to the machine. RAMCO is not responsible for accidents and damages caused by ignoring safety regulations and instructions.

To ensure proper operation and operator safety, following these guidelines:

1. Before operation, check that all warning symbols are clearly displayed in their proper positions. Any missing or unclear symbols must be immediately repaired.
2. Check that the over-vibration switch is in good condition.
3. Check interlocking condition of the door.
4. Open the loading door and attempt to start the machine. It should not start.
5. Close the loading door and start the machine. Try to open the door while the machine is operating. The door should not open.
6. Check the drainage valve and try to drain it. The valve should properly open and close.
7. Make sure the machine is in a good working condition. All spare parts are original parts.
8. Make sure the electrical panel door is closed and secured.
9. Make sure all panels are installed and secured.

NECESSARY DAILY REGULATIONS

1. Before repair or maintenance, machine operators must be familiar with all chapters of this manual.
2. Before maintenance, the water, steam, and power **MUST** be cut off. Lock out and tag the machine you are working on.
3. Overloading or under loading is not allowed. Each machine has a rated capacity that must be adhered to.
4. Before operation, start the air compressor. The machine can operate until the pressure reaches 55-75 psi.
5. Switch on the power and check the rotation direction of the drum while the water is being extracted. Viewed from the front, it should rotate **clockwise**.
6. While distributing, water must reach the required level to avoid over-vibration.
7. After extracting, do not press any key washing program or force to open the door.
8. While extracting, if the air pressure is too low or the drain valve has any problems, the operator should stop and check the machine immediately to avoid damage caused by overloading. Call Maintenance or a qualified person to work on the machine.
9. Do not manually cut-off power and air to the machine while washing/extracting.
10. Do not start and operate the machine if any panels are not installed.
11. To avoid any accidents while washing, operator should not leave the machine unattended.
12. Only trained personnel should make changes to machine settings.
13. Immediately adjust or replace aged or leaking parts.
14. Make sure the machine has been firmly secured to the ground. Check anchor bolts to make sure they are all tight. Bolts need to be checked 24 hours after startup and again after 40 hours.
15. If the water level is too low during automatic operation, press the **Cold Water** button until the required water level is reached.
16. Always check the working condition of each sensor.
17. Check the water level sensor to make sure the tested valve is in accordance with the actual number.
18. Check each thermal sensor to make sure the temperature displayed is correct.
19. Check the pressure gauge to make sure it is in a good condition and at the proper pressure.

20. Check all the belts; if any are loose immediately tighten them.
21. During maintenance, do not spray the machine with water to avoid short circuiting and other damage.
22. Do not use or place any volatile, flammable, or explosive materials inside or near the machine.
23. Make sure all cooling fans on electrical panel, inverter, and motor are free from lint. This could cause early failure of the motor and inverter which would not be covered under warranty.

MAINTENANCE

RAMCO laundry machines are well designed and manufactured. Daily maintenance is reduced as much as possible, but some necessary daily maintenance is required. When the daily maintenance routine is followed, the machines will have a long service life.

DAILY MAINTENANCE

1. Before operation, confirm that the over-vibration system is in a good working condition.
2. Before operation, confirm that door interlocks function is in good working condition.
3. Check the drain valve for leaks and proper operation.
4. Clean and flush the soap dispenser and clean the box cover. Do not let chemicals accumulate.
5. Clean the front, rear, and side panels.
6. Drain the water from the air filter and inject lubricant (sewing machine oil) via an oil atomizer. Water should not be present. If so, check air compressor. This will cause the solenoid valves to stick.
7. Check all solenoid valves to make sure there are no leaks.
8. Carefully check the door seal condition. If there are any leaks, immediately do maintenance or replace the door seal. To prevent door seal leaking, leave door open.
9. Clean the lint from the inverter fans in the electrical panels. Only qualified persons should open the electrical panel.

WEEKLY MAINTENANCE

1. Inject lubrication grease or oil at all lubrication points (the main bearing, spherical plain bearing, etc.)
2. Clean, dust, and add lubricant of each valve and cylinder's movable parts.
3. Check the condition of the V belt and check the alignment condition between the two sheaves.
4. Check the drainage pipe for leaks.
5. Check all water inlet pipes for leaks.
6. Check the safe range of over-vibration switch stroke. (Figure 7.8)

MONTHLY MAINTENANCE

1. Dismantle and clean the mesh filter in the strainers. If there is any blockage, clean or replace the filter.
2. Clean the inside of the machine. Make sure that no electrical component is moist or covered with dust. Turn off the power to the machine and lock out and tag the machine you are working on. Only qualified personnel should do maintenance or repairs on the machine.
3. Check all water and steam pipe hoses. If aging is found, replace the hose.
4. Check the condition of all the connectors every month.
5. Check all bolts and fasten them, if necessary. Check the anchor bolts.

Warning: Before any maintenance, make sure the main power of the machine has been turned off! Lock out and tag the machine you are working on.

Attention: After weekly and monthly maintenance, all panels must be returned to their original locations.

YEARLY MAINTENANCE

1. Check the working condition of each motor and make sure they are in good condition. Remove all dirt and lint.
2. Replace seriously damaged or worn parts, such as belts.
3. Check bumper springs to make sure they are in good condition.
4. Do a rust prevention treatment for the machine.

Attention: To avoid any injuries, maintenance must be done carefully. All maintenance and repair materials and parts must be in accordance with the machine requirements. If there are any questions, contact RAMCO. Loss or harm will occur if the machine is improperly maintained or repaired. Damage caused by not properly following the maintenance routine is not covered by RAMCO's warranty. Any replacement parts must be RAMCO-approved parts. Warranties can be voided if inferior or non-factory parts are installed.

STAINLESS STEEL MAINTENANCE

To protect stainless steel and prolong its service life, the surface of the washer must be maintained.

1. Most importantly, keep the machine clean. Detergent and water removes general dirt and grease. If possible, the operator should use a soft cloth to clean the washer's surface. Regular cleaning maintains a bright and anti-corrosive surface.
2. Remove the dirt in the gaps and at corners of the stainless steel. To avoid scratch marks if using an abrasive cleaning agent, the operator must wipe the surface along the same lines as the stainless steel lines.
3. Never use primary steel wool or a steel brush to clean the washer. If steel wool or a steel brush is used, carbon steel grains will be inlaid into the stainless steel surface and will cause rusting. The operator can use stainless steel wool or another non-metal, soft brush.
4. Keep the stainless steel from contact with other metals. If stainless steel comes into contact with salt or an acid solution, corrosion will occur.
5. Discoloration caused by overheating and contact with colored materials can be removed by using a powdered agent or special chemical solvent.
6. Keep stainless steel from long-term contact with wood or carbon steel.
7. Do not keep sterilization or bactericidal solvent in a stainless steel container for any length of time. Chlorine is a solvent which corrodes stainless steel.
8. Parts made of iron or steel, such as nails or screws, will rust and affect stainless steel. To alleviate this problem, paint a thick protective coating on carbon steel.

Attention: All cleansers and chemicals used for cleaning inside or outside of the washing machine must follow manufacturer's instructions. Some cleansers are poisonous or flammable. If used improperly, harm may occur. Never use a volatile solvent, such as acetone, banana oil, enamel reducer, tetrachloroethylene, gasoline, benzol, or other volatile oil as a cleaning agent!

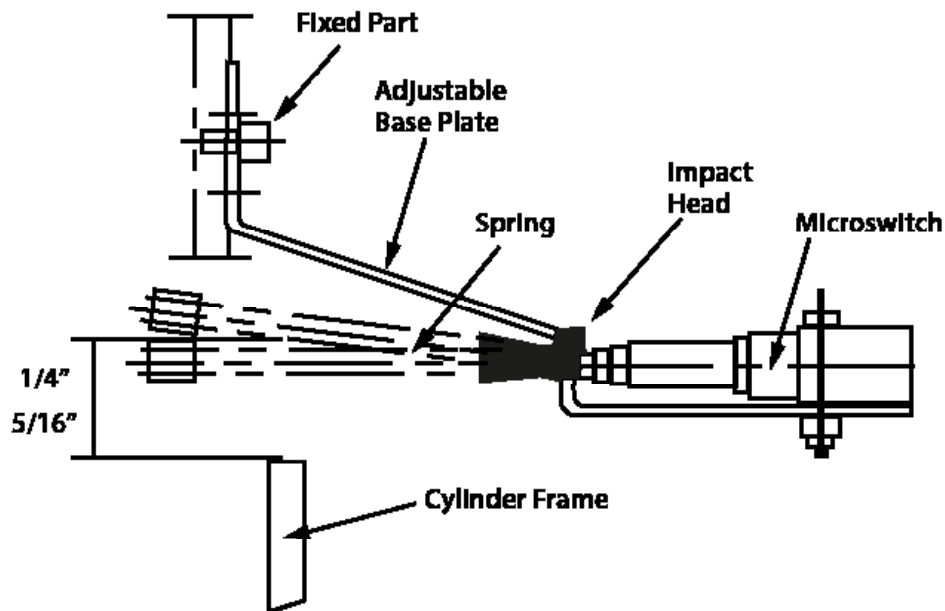

7.8 Over-Vibration System